

VALLA 20 TRACKED CRANE MAX. CAPACITY **Kg.2.000**



ELECTRIC BATTERY POWERED

CRANE FRAME: fabricated from preformed and welded steel plate. Standard carry deck

TRACTION: electric motor AC 12 kW – 48 V

TRANSMISSION: automatic, hydrostatic. Max speed 2 km/h.

TRACKED UNDERCARRIAGE: rubber tracks

HYDRAULIC SYSTEM: gear pump, electric proportional distributor with remote control, filter, safety valves on all boom operations. Max Hydarulic pressure 200 Bar.

BOOM: 1 fixed, 1 hydraulically telescoping section and 1 manually telescoping. Adjustable nylon wear pads on the sides.

LMI: Electronic Load Moment Indicator. Display showing lifted load, max allowed load, tilting percentage, operating radius, angle, telescope and light indicators on the operative mode.

TOTAL WEIGHT: approx. kg. 2.100

MAX. CAPACITY: kg. 2.000

Options on request: man bucket, radio remote control, hydraulic winch, hydraulic chain hoist, manual jib extension, non-marking tracks.



DIESEL POWERED

CRANE FRAME: fabricated from preformed and welded steel plate. Standard carry deck

ENGINE: Diesel HP 16,5 – 4 Cylinders, water cooled

TRANSMISSION: automatic, hydrostatic. Max speed 2 km/h.

TRACKED UNDERCARRIAGE: rubber tracks

HYDRAULIC SYSTEM: gear pump, electric proportional distributor with remote control, filter, safety valves on all boom operations. Max Hydarulic pressure 200 Bar.

BOOM: 1 fixed, 1 hydraulically telescoping section and 1 manually telescoping. Adjustable nylon wear pads on the sides.

LMI: Electronic Load Moment Indicator. Display showing lifted load, max allowed load, tilting percentage, operating radius, angle, telescope and light indicators on the operative mode.

TOTAL WEIGHT: approx. kg. 1.900

MAX. CAPACITY: kg. 2.000

Options on request: man bucket, radio remote control, hydraulic winch, hydraulic chain hoist, manual jib extension, non-marking tracks.

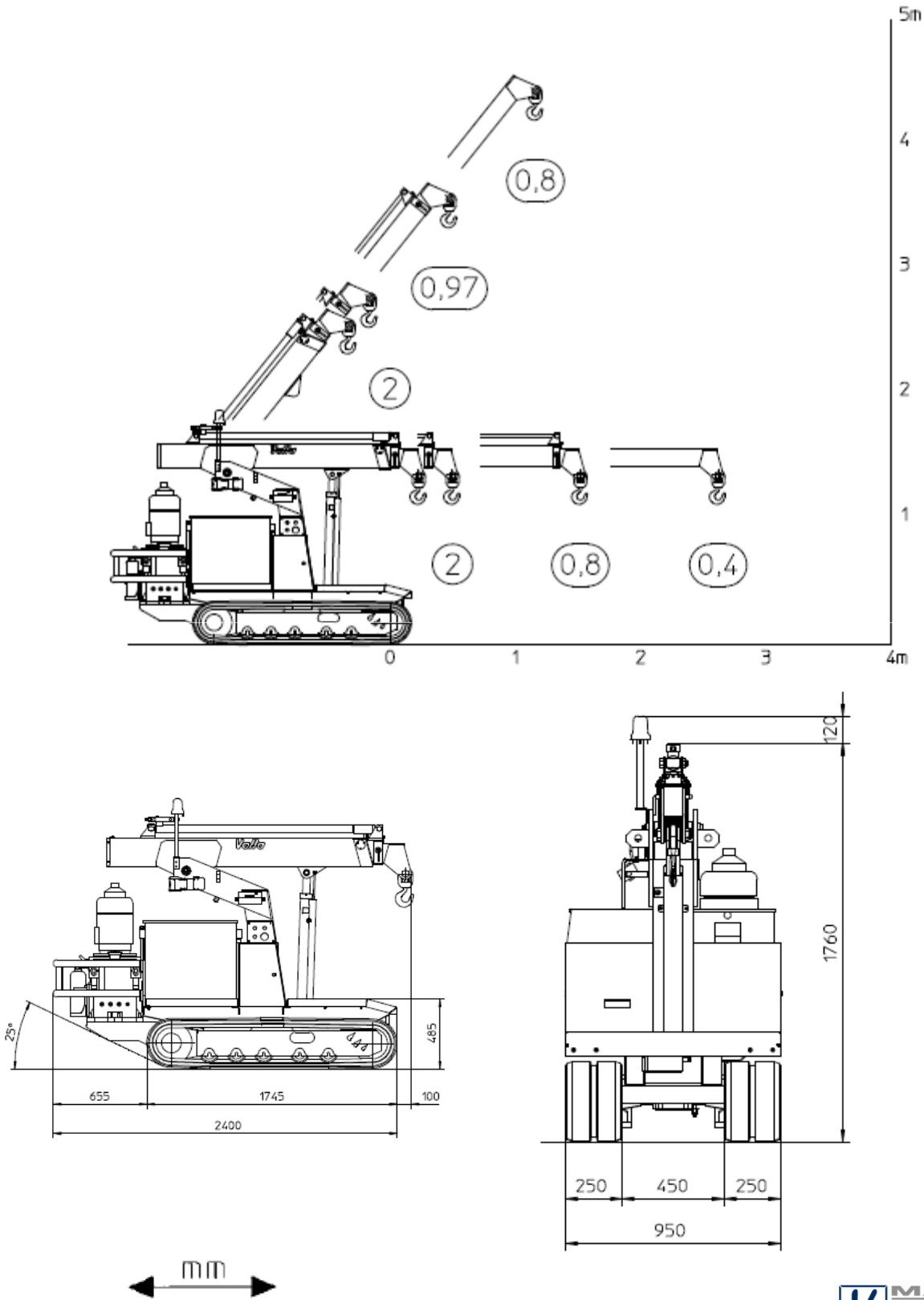

Data subject to be changed without any previous notice. Pictures may differ from technical description.

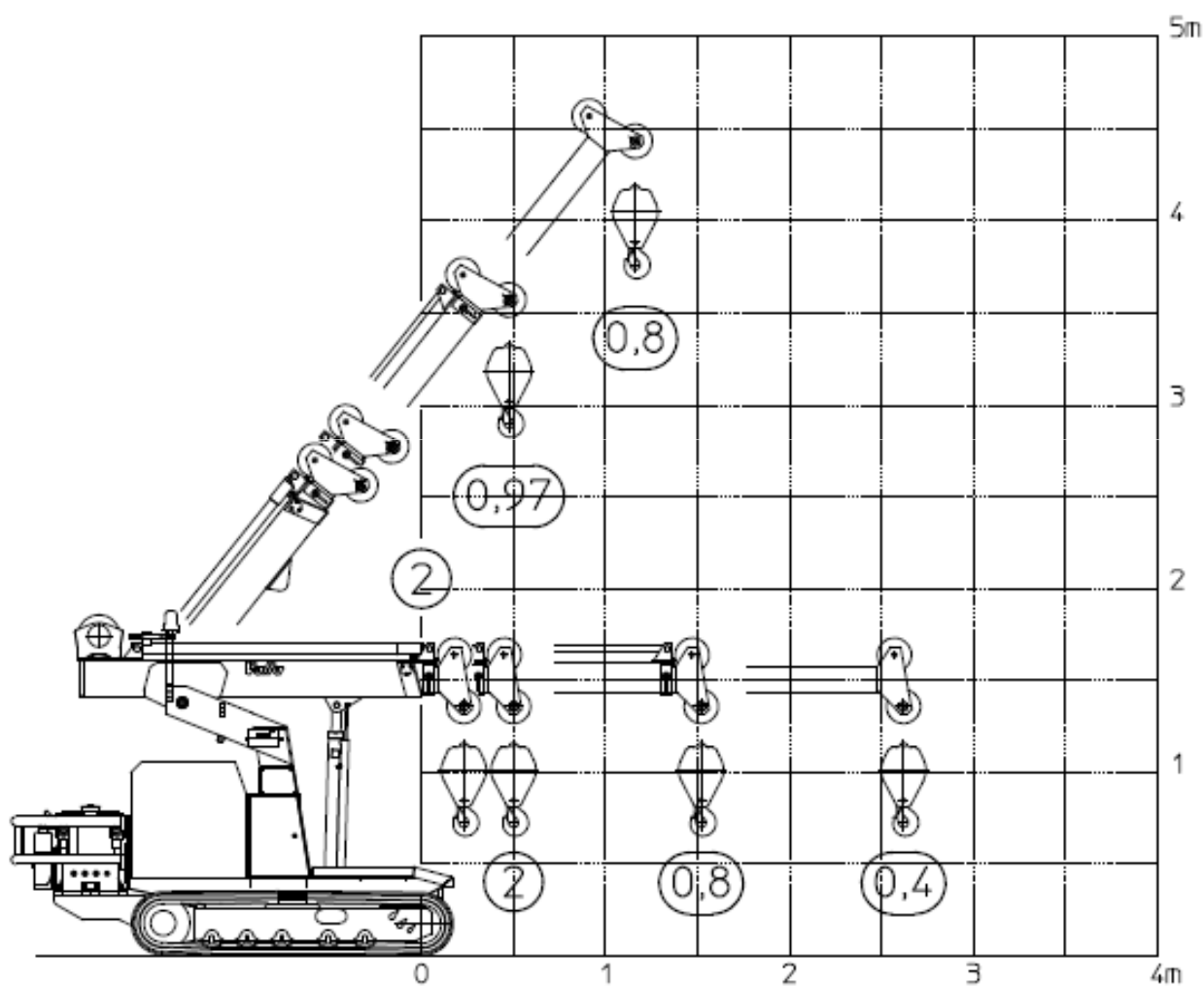

Data subject to be changed without any previous notice. Pictures may differ from technical description.



Sede Operativa:
Via Emilia Loc. Favorita - 29010 Roveleto di Cadeo (PC) - Italy
MANITEX INTERNATIONAL Inc. Group

