

# ML 3.0 FX ATTACHMENTS

CRAWLER CARRIER



**ALMACRAWLER** 

# ML 3.0 FX ATTACHMENTS

The ML 3.0 FX comes with a wide range of **fully installable, completely independent attachments** to amplify its range of applications and allow operators to achieve more.

Il ML 3.0 FX è dotato di un'ampia gamma di accessori autonomi, facilmente installabili, che permettono di ampliare la gamma di applicazioni del trasportatore cingolato.



**KML 1.0**

	KLM 1.0		KLM 2.0		
	METRIC	IMPERIAL	METRIC	IMPERIAL	
Max capacity	<b>1000 Kg</b>	<b>2200 lbs</b>	<b>400 Kg</b>	<b>880 lbs</b>	Capacità max
Weight (empty)	<b>415 Kg</b>	<b>915 lbs</b>	<b>490 Kg</b>	<b>1080 lbs</b>	Peso (a vuoto)
Weight on ML 3.0 FX ELC	<b>1205 Kg</b>	<b>2655 lbs</b>	<b>1280 Kg</b>	<b>2820 lbs</b>	Peso sul ML 3.0 FX ELC
Weight on ML 3.0 FX LTH	<b>1135 Kg</b>	<b>2500 lbs</b>	<b>1210 Kg</b>	<b>2667 lbs</b>	Peso sul ML 3.0 FX LTH
Battery	<b>12 V 100 Ah with charger on board (110V-230V)</b>		<b>12 V 100 Ah with charger on board (110V-230V)</b>		Batteria



## Self-standing kit

Kit autoportante



**KML 2.0**

## Lifter KIT

Fully removable hydraulic scissor lift table available in two options

Piano a forbice completamente rimovibile disponibile in due opzioni

**KML 1.0**

Single stage

**KML 2.0**

Double stage

# KDM13

# Dumper

Installable dumper kit  
 Rotating base  
 Radio remote controlled

Kit dumper installabile  
 Pianale ruotante  
 Radiocomando

## Swivel platform

Rotazione del pianale



### KDM 13

	METRIC	IMPERIAL	
Max capacity	<b>1300 Kg</b>	<b>2870 lbs</b>	Capacità max
Weight (empty)	<b>655 Kg</b>	<b>1445 lbs</b>	Peso (a vuoto)
Struck volume	<b>0.6 m3</b>	<b>21 ft3</b>	Volume raso
Rated volume (ISO 6483)	<b>0.65 m3</b>	<b>23 ft3</b>	Volume max (ISO 6483)
Battery	<b>12 V 100 Ah with charger on board (110V-230V)</b>		Batteria
Weight on ML 3.0 FX ELC	<b>1445 Kg</b>	<b>3185 lbs</b>	Peso sul ML 3.0 FX ELC

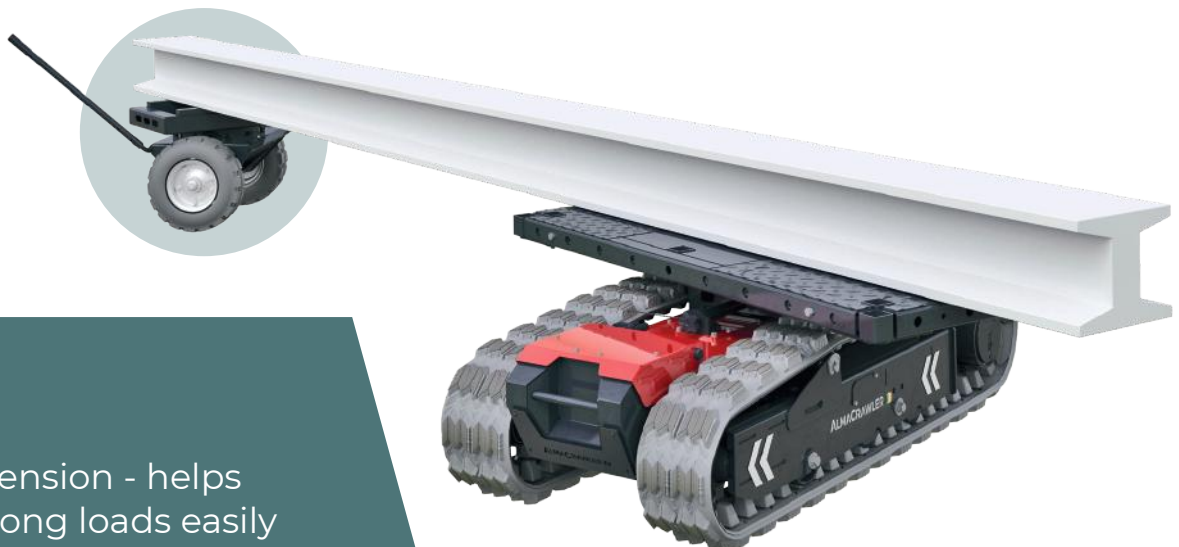

# Dolly

Support extension - helps carry extra-long loads easily

Accessorio estensivo del pianale: aiuta a trasportare facilmente i carichi più lunghi

**Max capacity** 1500 Kg / 3310 lbs

**Weight (Peso)** 96 Kg / 210 lbs



# Multiframe

Double-sided a-frame rack for the safe transport and storage of windows, flat glass or insulating glass units.

A-Frame per il trasporto sicuro di finestre, vetri piani o vetrate isolanti.



**Max capacity** 2400 Kg / 5290 lbs  
(1200 Kg / 2645 lbs for each side)

**Weight (Peso)** 145 Kg / 320 lbs

# Battery Trolley

Custom design trolley to allow easy removal and storage of battery pack.

Trolley progettato su misura per estrarre e trasportare facilmente la batteria.



**Max capacity** 170 Kg / 375 lbs

**Weight (Peso)** 30 Kg / 66 lbs

**ALMACRAWLER** 

# ML 3.0 FX ATTACHMENTS

## Multiframe

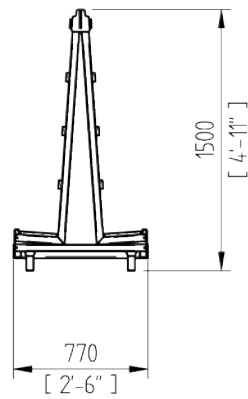
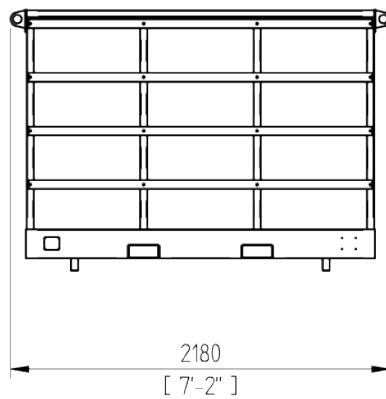
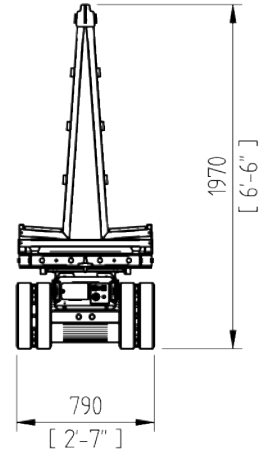
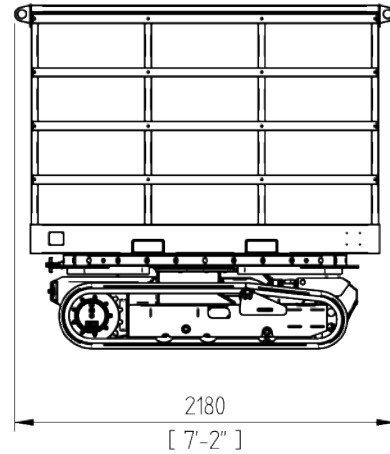

## Battery trolley

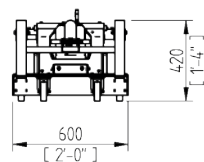
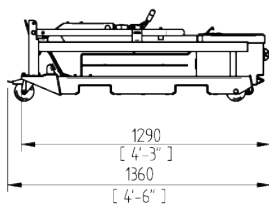
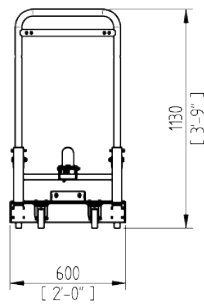
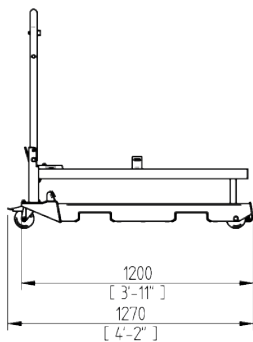
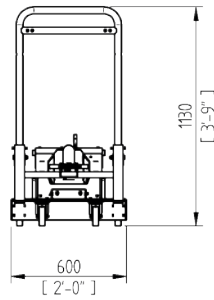
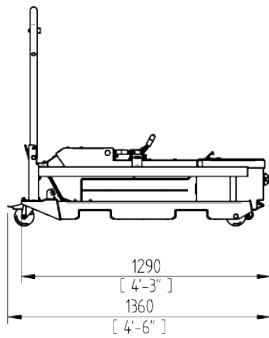

## Dolly

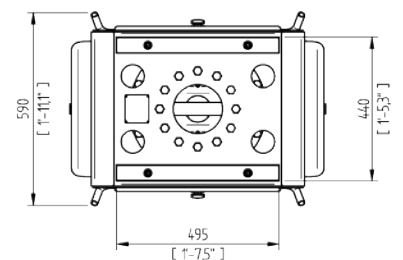
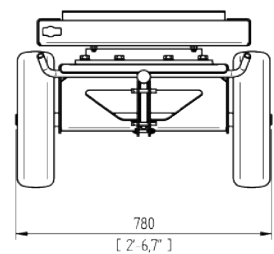
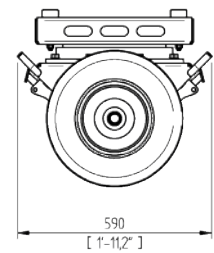

## Lifter kit single stage KLM 1.0

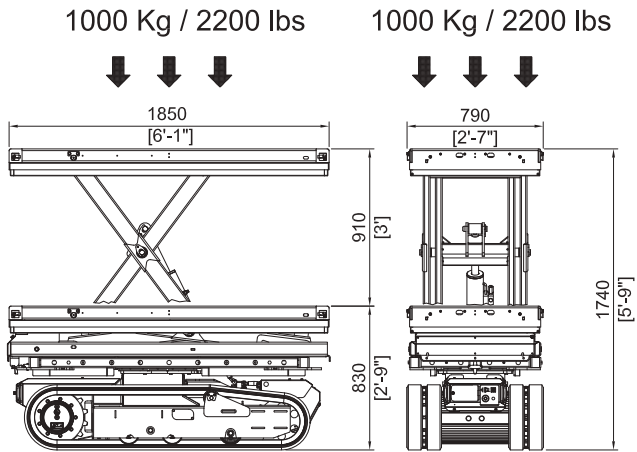

## Lifter kit double stage KLM 2.0

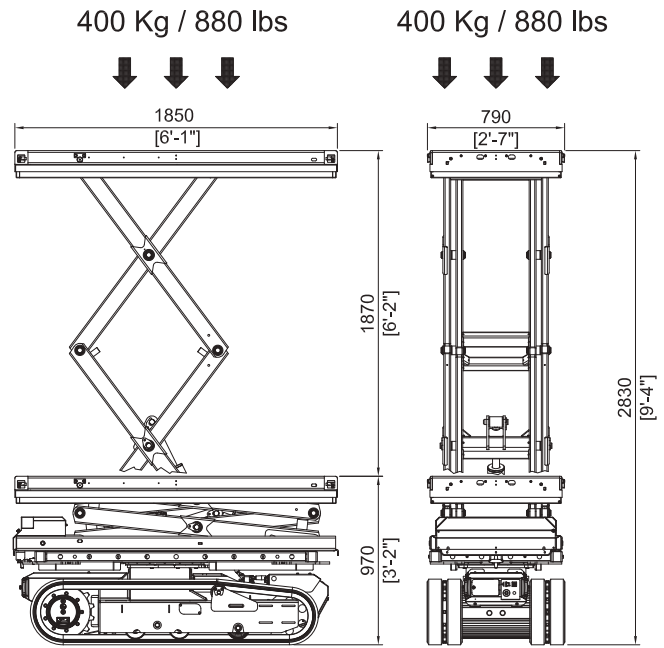

## Dumper KDM13

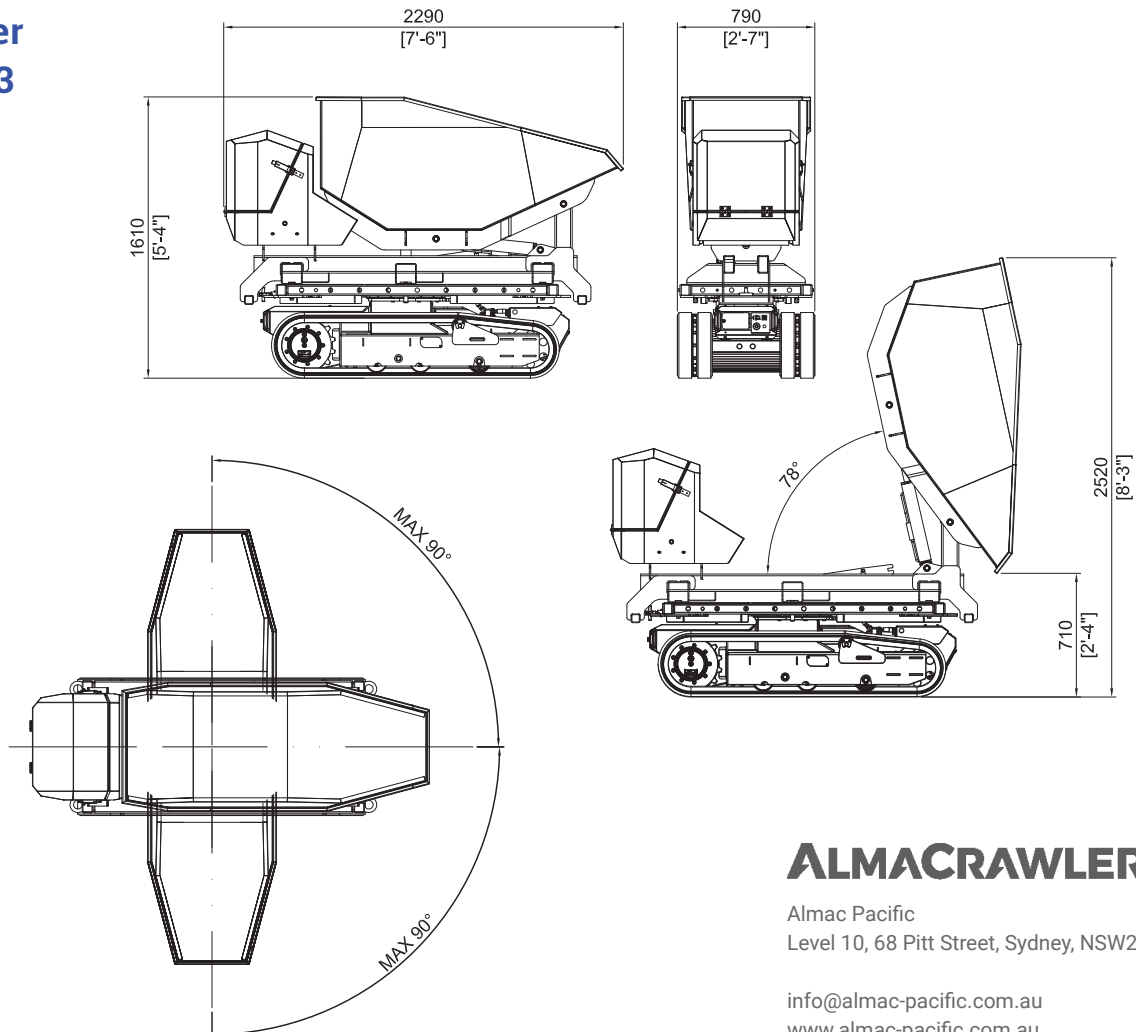

**ALMACRAWLER** 

Almac Pacific  
Level 10, 68 Pitt Street, Sydney, NSW2000

info@almac-pacific.com.au  
www.almac-pacific.com.au