

16,330 kg Max. Capacity

- Rated Capacity Limiter ... Standard
- Capacity on Outriggers ... 16,330 kg
- Pick and Carry Capacity ... up to 8,400 kg
- Height ... 2.41 m
- Width ... 2.39 m
- Boom Rotation ... 360 Degree Continuous
- Sheave Height ... up to 24.23 m
- Horizontal Reach ... up to 21.36 m
- Tight Turning Radius
- 4-Wheel Steer ... Standard
- 4-Wheel Drive ... Optional
- Powershift Transmission ... Standard
- Fully Hydraulic Controls for Smooth Precise Operations
- Independent Outrigger Controls
- Diesel or LPG Fueled Engines Available

BRODERSON[®]
Manufacturing Corp.



IC-250-3C

CAPACITIES ARE IN KILOGRAMS AND APPLY TO OPERATION ON FIRM LEVEL SURFACE

LOAD RADIUS METERS	MAIN BOOM		MAIN BOOM OR BOOM EXTENSION					
	ON RUBBER	ON RUBBER	O/R'S IN & DOWN	O/R'S IN & DOWN	O/R'S OUT & DOWN			
	360° ROTATION	OVER FRONT	360° ROTATION	OVER FRONT	360° ROTATION			
1.8	7440	8400	13600	16330	16330			
2.0	6900	7880	12960	15600	15600			
2.5	5790	6680	11140	13540	13540			
3.0	4970	5680	9370	11530	11530			
3.5	4280	4930	7590	9770	9770			
4.0	3690	4350	6050	8890	8890			
4.5	3210	3860	4980	8130	8130			
5.0	2840	3440	4240	7400	7400			
6.0	2230	2820	3210	6220	6220			
7.0	1760	2280	2470	5210	5210			
8.0	1380	1780	1870	4410	4410			
9.0	1100	1430	1440	3800	3800			
10.0	860	1130	1130	3330	3300			
11.0	680	900	900	2960	2850			
12.0	520	730	710	2540	2400			
13.0	380	610	570	2210	2080			
14.0	270	500	500	1930	1820			
15.0	190	420	360	1700	1590			
15.2	160	410	320	1650	1540			
16.0	---	---	---	---	1610			
17.0	---	---	---	---	1520			
18.0	---	---	---	---	1360			
20.0	---	---	---	---	1080			
21.3	---	---	---	---	950			
BOOM EXT OFFSET ANGLE	6.1M BOOM EXTENSION STRUCTURAL CAPACITIES- STRAIGHT OR OFFSET							
	MAIN BOOM ANGLE							
	0°	15°	30°	40°	50°	60°	70°	75°
0°	1180	1250	1360	1540	1860	2310	2810	3170
15°	---	1130	1180	1220	1310	1490	1950	2180
30°	---	---	1040	1090	1130	1220	1450	1540

CAUTION BOOM EXTENSION LOADS MUST NOT EXCEED MAIN BOOM CAPACITY. BOOM EXTENSION MAY ONLY CARRY LOADS WITH OUTRIGGERS DOWN. CAPACITIES ON OUTRIGGERS ARE 85% OF TIPPING LOADS. CAPACITIES ON RUBBER ARE 75% OF TIPPING LOADS. CAPACITIES BELOW BOLD LINE ARE LIMITED BY TIPPING. OTHER CAPACITIES ARE LIMITED BY STRUCTURAL OR HYDRAULIC CAPABILITY.

BOOM EXTENSION DEDUCT: 225 kg WHEN STOWED ON BOOM

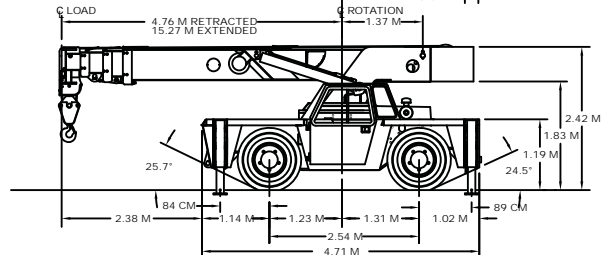
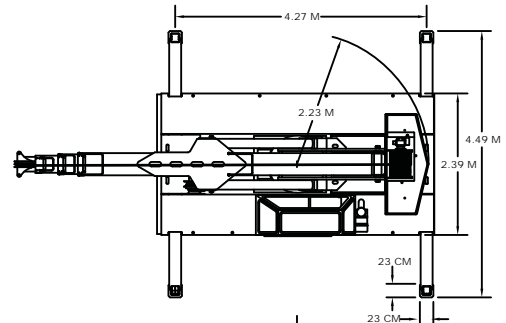
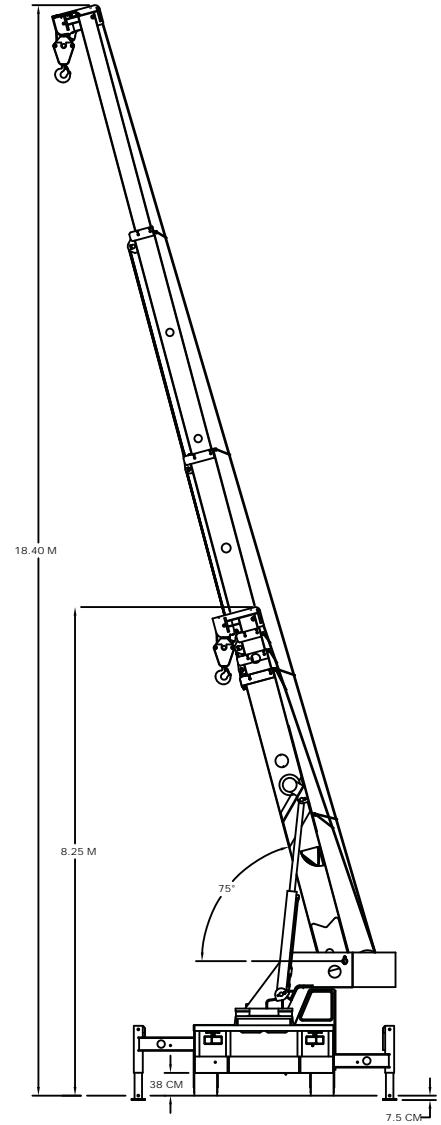
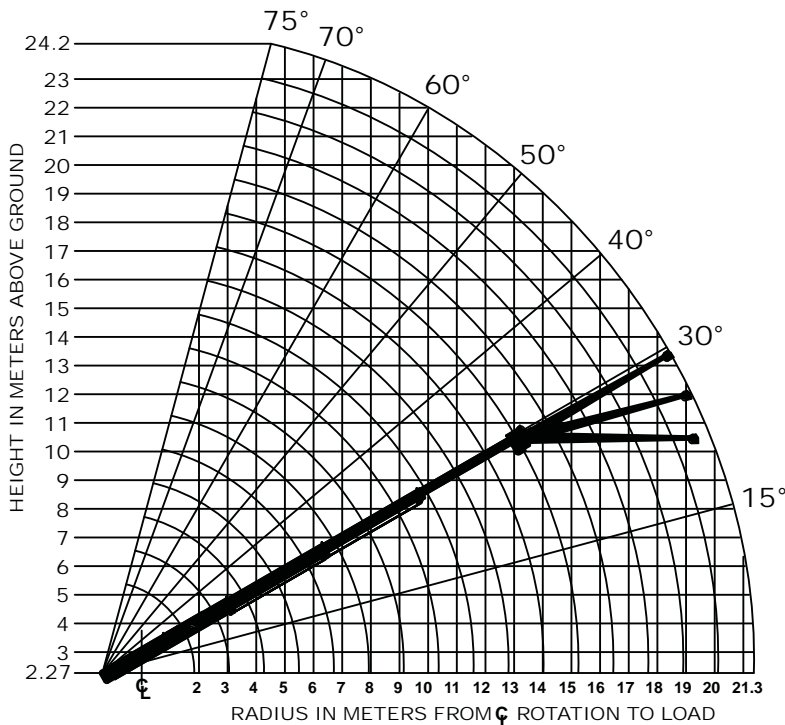
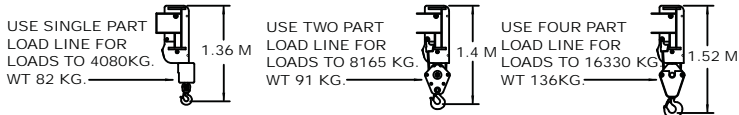

IC-250-3C

Specifications

GENERAL:

Boom Movement:	Rotation	Elevation	Extension*
	Continuous	0° to 75°	34' 6"
Boom Speeds:	2.0 RPM	24 sec.	53 sec.
	*(with synchronized hoist cable)		
Weight:			
Total	17,100 kg		
Front Axle	7,900 kg		
Rear Axle	9,200 kg		
Gradeability:	64%		
Turning Radius:	4.37 m		

ENGINE:

Make	Cummins	GM
Model	QSB3.3 L	5.7 L
Type	Turbocharged-Diesel	LPG (Woodward)
No. Cyl.	4	8
Displacement	3.3 L	5.7 L
HP @ Gov. Speed	74 kw	100 kw
	US EPA Tier 3	US EPA Tier 2
Fuel Tank Capacity	114 L	2-19.5 kg LPG tanks

TRANSMISSION:

Powershift transmission with 4-speeds forward & reverse. Provides power shifts at any engine speed in any gear. All shifting is done with a single lever electrical control mounted on the steering column. Equipped with torque convertor & transmission oil cooler. Torque convertor has stall ratio of 2.2:1.

Gear Ratio:

First	5.72:1	Third	1.77:1
Second	3.23:1	Fourth	1.00:1

AXLES:

Front Axle:

Planetary drive/steer front axle with 15.78 to 1.0 ratio. Differential equipped with "limited slip" feature. Front axle mounted rigidly to frame.

Gear	Travel Speed	Drawbar Pull*
First	5 km/h	8,440 kg*
Second	8 km/h	4,850 kg*
Third	16 km/h	2,630 kg*
Fourth	29 km/h	1,410 kg*

*Drawbar pull is calculated.

Rear Axle:

Standard (2-Wheel Drive):

Steering axle with 1-1/2 degree oscillation in either direction.

Optional (4-Wheel Drive):

Planetary drive/steer axle with 24.98 to 1.0 ratio. Differential is not "limited slip" in rear axle. 1-1/2 degree oscillation in either direction. Axle ratio compatible with 4-wheel drive transmission output for front axle match. Transmission equipped with electro-hydraulic control for shifting between 2-wheel drive & 4-wheel drive.

STEERING:

Hydraulic steering unit with two cylinders attached to each axle. Rear axle is the primary steer. An electric switch on the operator's compartment is used to select rear-wheel steering, four-wheel steering round steer or crab steering. Electronic sensors & control box automatically align the steering when a new mode is selected.

BRAKES:

Service: Split-system, 4-wheel hydraulic-boosted multiple-plate wet disc brakes.

Parking: Hand lever actuated disc-type parking brake on transmission.

TIRES:

385/65D22.5, 16-ply, high-traction on/off road tread.

CHASSIS:

CARGO DECK:

74 m² of deck area. 7,700 kg capacity on deck when load is centered over or between axles.

Headlight & Taillight Grilles:

Steel protective grilles for headlights & taillights. Easily removable for replacing bulbs.

OUTRIGGERS:

Four hydraulic out & down outriggers of box beam construction with direct-connected holding valves. Independent controls for each outrigger. Outrigger pad dimension 22.86 cm x 22.86 cm.

ACCESSORY STORAGE BOX:

Storage box is 36 cm deep x 32 cm long x 93 cm wide, located in front cargo deck.

Lifting Rings

Lifting rings at each corner of cargo deck so sling can be attached for lifting crane.

OPERATOR COMPARTMENT:

Provides one-position access to all chassis & crane functions. Includes adjustable operator's seat, retracting seat belts, fire extinguisher & bubble level.

ELECTRICAL:

12 Volt System

Lighting Package:

One pair headlights with high & low beams, tail, brake & turn signal lights & back-up lights in rear, turn signals & emergency flasher switch at operator's station.

Instrument Package:

Fuel gauge and hourmeter records hours only during engine operations. Also includes warning lights for low oil and transmission pressure, check engine, high coolant and transmission temperature, turn signals, high beams, hazard lights, park brake & four-wheel drive.

Back-Up Alarm:

Provides pulsating sound from 97dB alarm when transmission is in reverse.

Outrigger Alarm System:

Two-tone alarm is activated when "outrigger down" or "outrigger out" controls are operated.

HYDRAULIC SYSTEM:

Tandem pump, direct-driven by engine crankshaft, rated at 108 & 129 l/m at rated RPM. Hydraulic oil tank capacity of 204 liters.

BOOM ASSEMBLY:

Four-section boom assembly equipped with bearing pads, double-acting hydraulic cylinder & chain system telescopes booms proportionally. Telescope & boom elevation cylinders equipped with cylinder-mounted holding valves. Boom angle indicator on left hand side of boom.

Boom Rotation:

Heavy-duty ball bearing rotation gear with external teeth. Rotation is powered by hydraulic motor & worm gear drive.

Boom Hoist:

Turret mounted planetary gear hoist hydraulically powered with a bare drum line pull of 5,440 kg & a line speed of 30 m per minute. Includes downhaul weight, swivel hook & sheave block for 4-part line & 97.5 m of 14.3 cm hoist rope.

Anti-Two-Block Device:

Prevents damage to hoist rope and/or crane components from pulling load hook against tip.

Rated Capacity Limiter:

Warns operator of impending overload with audible & visual signals. Prevents overload by stopping boom functions that cause overloads.

